

GO₂™ for MUNICIPAL WATER

GO₂ (ClO₂) is 10-times more powerful in its disinfection strength than standard Chlorine. GO₂ addresses specific disinfection tasks that Chlorine cannot accomplish and has a far longer effective life. In addition, to purifying drinking water, GO₂ also removes biofilm in water pipes, tanks and distribution systems. Chlorine does not address this important issue. Unlike Chlorine, GO₂ has no known negative side effects. 1 ppm GO₂ delivers the same disinfecting power as 10 ppm Chlorine. The dilution factor plays an important role in safety and cost comparison. Additionally, GO₂ is harmless, whereas Chlorine is dangerous to use and has harmful side effects on human, animal, plant and marine health.

In water treatment, many variable factors apply. This makes it difficult to create a standard model to compare GO₂ with Chlorine. The most important factor is local regulation prescribing allowable concentration levels of Chlorine in drinking water. The concentration level depends on the existing water quality, the quality of the local pipe distribution network, the history of water treatment, the quality of maintenance at the water treatment facility and the distribution system, and the ppm level required at the tap, as prescribed by local authorities. The World Health Organization (WHO), based on recommendations from the German Government TVO and DVGW, which has the world's highest water quality standards, has set the maximum safe concentration of Chlorine Dioxide in drinking water at 0.7 ppm. This refers to the concentration level of Chlorine at the tap, not at the water plant. For standard drinking water, a concentration of 0.7 ppm as a constant level at the tap is actually a very high level to apply.

An important factor is to have zero contamination in water coming out of the tap. This depends on the original water quality, and also determines the Chlorine concentration required to have long-term, clean, disinfected water.

In existing water distribution systems, the distribution pipes are permanently contaminated with biofilm. The biofilm consists of two layers. There is a hard layer compacted against the inner wall of the distribution pipe. Within the hard layer is a soft biofilm layer. The soft layer deposits flakes of biofilm into the water current. The biofilm deposits block piping systems, drinking water nozzles and cleaning sprays, etc. Chlorine does not eliminate, or even inhibit, the growth of biofilm.

What is GO₂?

GO₂ is the 21st Century replacement for environmentally harmful chlorine, which has been in use for over a century to disinfect drinking water. GO₂ is an advanced chemistry to generate chlorine dioxide (ClO₂) in solution with a purity of 95.0+%. Pure ClO₂ is ten times more powerful as an oxidizing biocide than chlorine and chlorine-type disinfectants. GO₂ produce only trace amounts of chlorine, chloramines, chlorites and chlorides, and meets all safety levels approved by the EPA and other regulatory agencies. GO₂ kills all water-borne micro organisms. These include bacteria, including coliform, salmonella, listeria, E-coli, cinobacteria, viruses, yeast, fungi, mold, algae, spores, protozoans, cryptosporidia, actinomycetes, cysts, giardia, legionnaire's disease, cholera, dengue, hepatitis and typhoid. GO₂ also kills airborne viruses when misted into air or used on contaminated surfaces via HVAC or spray system distribution, including anthrax, influenza, SARS, smallpox, chickenpox and avian flu. The range includes not only viruses which infect humans but viruses that kill poultry, fish and livestock. GO₂ also removes phenols, cyanides, iron, manganese and ethnogeny from water. GO₂ 100% eliminates microbial slime from water distribution and storage systems, whether this contamination is in a simple village well, a farm drinking water or irrigation system, or in an entire city.

GO₂ is manufactured in powder form. Combination of two separate components in simple tap water produces a 95.0% pure ClO₂ solution at a concentration of 4,000 ppm. This concentrate is then simply dosed into the target water to produce safe, disinfected water. Minimal investment in equipment or infrastructure is required to use GO₂ just a simple dosing pump and a ClO₂ measuring device. The product is safe and simple to use, transport and store. It has a shelf life of 5 years. One gallon of GO₂ will treat 4,000 gallons of water @ 1.0 PPM.

GO₂ is US NSF-60 approved. US EPA, FDA and USDA approval will be granted in Q2, 2009. The product meets the highest standards established by European Agencies governing the safety and hygiene of human drinking water.

The concentrate should be stored in a cool, dark place. It will stay potent at 4,000 ppm concentration for 15 days. Thereafter it will gradually decline in strength, retaining 50.0% potency up to 30 days. For all practical purposes, the ability to mix and use a batch of concentrate within 15 days is sufficient.

GO₂ customers include a variety of industries where safe water is required. These include drinking water from village wells to entire cities, waste water treatment, food and beverage producers, bottled water companies, agriculture, livestock, poultry,

dairy, fruit and produce washing, meat processing, the pulp and paper industry, the oil and gas industry, hotels, restaurants, hospitals, cruise ships and marine vessels, swimming pools, hot tubs and spas.

GO₂™ Key Features

- ▶ Eliminates microbial slime and prevent its reformation in drinking water and process water systems
- ▶ Reduces equipment needs and maintenance costs
- ▶ Improves water quality
- ▶ 2 simple powders mixed in tap water produces pure ClO₂ at 95.0% efficiency of conversion
- ▶ Environmentally safe chemistry
- ▶ Used as a water disinfectant in many countries for industrial, agricultural, municipal and consumer applications.
- ▶ Easy, safe and effective to use, store and transport
- ▶ Competitive use cost when compared to traditional treatments.

GO₂™ Applications

- ▶ Drinking Water Treatment
- ▶ Water Hygiene and Remediation
- ▶ Water Chiller and Cooling Tower Treatment
- ▶ Environmental Control
- ▶ Walls, Floor, Ceiling, Equipment Exterior, Hand & Foot, Fogging, Etc.
- ▶ Poultry, Beef Cattle and Dairy Cattle Drinking Water
- ▶ Beef and Poultry Carcass Washing
- ▶ Post-harvest fruit, vegetable and Produce Washing
- ▶ Food Processing Facilities
- ▶ Shelf-Life Extension
- ▶ Air Conditioning Systems
- ▶ Humidification Remediation and on-going Treatment

GO₂™ Unique Properties

1. Cleaning Properties

- ▶ Powerful inorganic Oxidizing Agent and free radical with residual cleaning ability
- ▶ Destroys algae-related taste and odor compounds
- ▶ Higher yield (up to 260% more oxidation output compared to chlorine)
- ▶ GO₂ does not chlorinate organic materials; so no Chloral-Phenols
- ▶ Only traces of byproducts (THM's, HAA's, MX and other compounds)
- ▶ Removes microbial slime for water distribution systems
- ▶ Steady bactericidal efficacy within a broad range of pH levels (pH 3 to pH 10)
- ▶ 100% effective against all water-borne micro-organisms and spore forming bacteria (Bacteria, Viruses, Protozoa, Fungi, Algae)
- ▶ No build-up of resistance in micro-organisms. Kills the cell RNA.



GO₂ comes in powder form. 20kg (44.0 lbs) of component A and 20kg of component B produces 1000 liters (264gal) of 4,000 PPM pure chlorine dioxide. Minimal equipment is required, only a mixing tank. GO₂ is a clean process; it is environmentally friendly, safe and produces zero by-products.

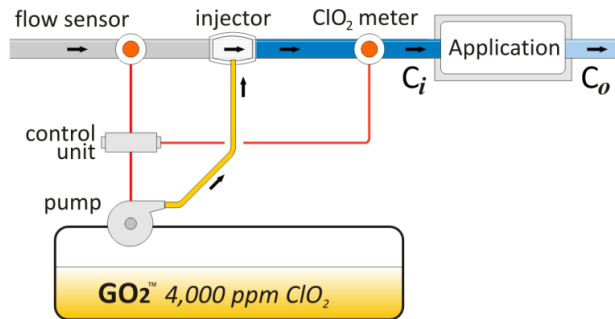

To apply GO₂[™], the only equipment required is a storage tank, a flow sensor and injector. These costs are minimal and eliminate investment.

2. Cost Properties

GO₂ eliminates the need for:

- ▶ Cost of a conventional ClO₂ Generator (cheapest approximately US \$10,000)
- ▶ ClO₂ Generator maintenance and re-certification
- ▶ Security Measures
- ▶ Risk and Liability Insurance policy
- ▶ Training, certification and re-certification of qualified personnel
- ▶ Environmental, Health & Safety factors
- ▶ HAZMAT for shipping Liquids
- ▶ GO₂ in a "Shoe Box" equals the volume of four x 55 gallon drums of conventional disinfectant liquid
- ▶ No additional chemicals are required (e.g. pH-level stabilizers)

GO₂ 4,000 ppm concentrate can treat the following amounts of water at 5 pre-set concentrations:

4,000 ppm kit for	1.0 ppm	0.5 ppm	0.3 ppm	0.2 ppm	0.1 ppm
264 Gal	1,058,201	2,116,402	3,527,337	5,291,005	10,582,011
1,000 Liters	4,000,000	8,000,000	13,333,333	20,000,000	40,000,000

3. Delivery Mechanism

- ▶ 5 years guaranteed shelf life in two-component form
- ▶ Easy to mix and use (standard industrial dosage equipment)
- ▶ 100.0% solubility in water
- ▶ Ready to use on site in 30 minutes
- ▶ 30-60 day shelf-life in 4,000 ppm concentrate form 48 - 72 hour biocidal life when added to water
- ▶ Produces 95.0% pure ClO₂
- ▶ High yield rate, one gallon of GO₂ treats 40,000 gallons of water @ 0.10 PPM ClO₂

4. Chemical Properties

- ▶ Does not react to water to form hypochlorous acid. No "free chlorine"
- ▶ No harmful By Products. Environmentally friendly.
- ▶ Unlike chlorine, GO₂ does not react with ammonia, ammonium or other organic compounds
- ▶ Trace amounts of un-reacted Chlorite, Chloride and Sulfate
- ▶ High efficiency in the removal of Iron and Magnesium compounds
- ▶ Reduces Sulfites to Sulfates

5. Operational Properties

- ▶ No residues
- ▶ Non corrosive to systems, pipes, pumps, filters, equipment
- ▶ Single-product water cleaner and conditioner
- ▶ Effective against airborne diseases when "misted"
- ▶ Inexpensive.
- ▶ Safe to use, handle, ship and store
- ▶ Improves performance of poultry and livestock

BIOFILM

In existing water distribution systems, the distribution pipes are permanently contaminated with biofilm. The biofilm consists of two layers. There is a hard layer compacted against the inner wall of the distribution pipe. Within the hard layer is a soft biofilm layer. The soft layer deposits flakes of biofilm into the water current. The biofilm deposits block piping systems, drinking water nozzles and cleaning sprays, etc. Chlorine does not eliminate, or even inhibit, the growth of biofilm.

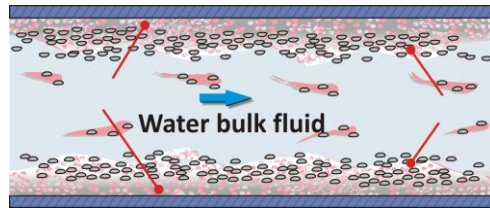

Tests with GO₂ showed that the inner thin layer of the biofilm was 100% removed after 7 days. The hard layer requires 60 to 120 days to remove, depending on the thickness of accumulation. In all cases the hard layer is completely removed. The process of decontamination is completely safe and has no adverse side effects.

Using GO₂, a treatment can be started with 2 ppm GO₂ (CLO₂) at the water plant, in order to yield 0.3 ppm concentration level at the tap. Over time, using GO₂, the biofilm in the distribution system and storage tanks is killed and removed, and the GO₂ concentration can be lowered.

For example, after the distribution system is cleaned, a concentration of 0.3 ppm GO₂ (CLO₂) at the water plant will still yield 0.1 ppm at the tap. These concentration levels can then be established as the stable application level, providing a consistent result in the water distribution system and at the tap. The fact that GO₂ is ten times more effective than chlorine, allowing less product to be applied to produce superior and longer lasting results, produces healthier drinking water at less cost to the city and to consumers than chlorine.

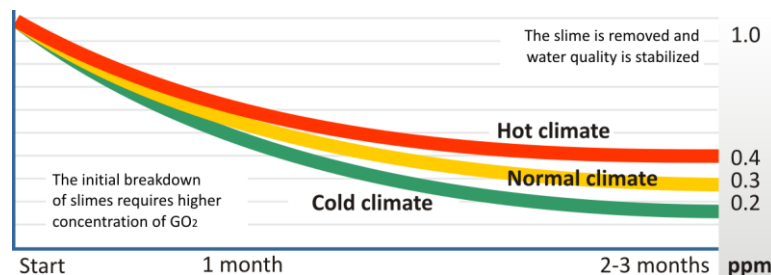
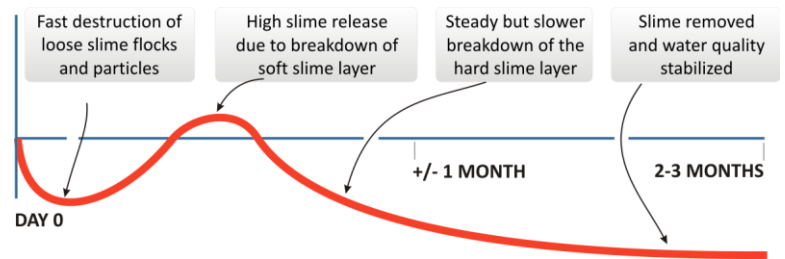

GO₂ PRODUCT REQUIREMENT

Production of clean drinking water requires two steps. The first is to produce a high concentrate. For example, production of 1,000 liters of 4,000 ppm GO₂ concentrate (CLO₂) per liter requires 1,000 liters of water, plus 20 Kg of GO₂ dry component "A" plus 20 Kg of GO₂ dry component "B". Based on the temperature of the water, it takes between 1 and 3 hours for components "A" and "B" to dissolve into 1,000 liters of water and to for 95%+ pure chlorine dioxide.

Then, using mechanical injectors, the 1,000 liters of concentrated GO₂ water is gradually blended into 6,000,000 liters of normal water to provide total disinfection. The infusion process produces pure drinking water with a GO₂ concentration of 0.5 ppm. This level of concentration kills all bacteria and prevents the re-occurrence of bacteria and biofilm in the distribution system.

Example

Demand: A sample city of 10,000,000 people, an estimated consumption of 50 liters of water per person, per day, and a required concentration at the tap of 0.1 ppm.

In this example, 12,500 liters of 4,000 ppm GO₂ concentrate, requires 12.5 x 20 Kg = 250 Kg of dry component "A" plus 250 Kg of dry component "B" per day to produce a standard of 0.1 ppm for this city.

The concentration initially required to clean water distribution systems from biofilm, tanks and distribution systems, might be higher, and gradually go down over time. Parameters like original water quality, condition of the pipe distribution system and local demands might cause a permanent higher concentration at the water treatment facility then the concentration at the tap. E.g. even after full cleaning of the piping network, in order to yield a 0.04 ppm at the tap, the input required at the water plant might be 0.06 ppm.



For municipal water, GO₂TM concentrate is pumped from 1,000 liter tanks into the drinking water system. No dangerous generators or specially secured area's are necessary.

Contact: Rich O'Reskie:
 Technical Director
 GO₂ International
 Tel: +1.877.369.4872 x103
roreskie@go2intl.com
 Cell: +1.952.250.0132

DISCLAIMER

We believe the information contained herein is accurate; however, GO₂ International makes no guarantees with respect to such accuracy and assumes no liability in connection with the use of the information contained herein by any party. The provision of the information contained herein and the provision of information by or reliance on GO₂ International. Technical and Environmental Services Department is not intended to be and should not be construed as legal advice or as ensuring compliance with any country, federal, state or local laws and regulations.

© GO₂ INTERNATIONAL

www.go2intl.com/copyrights

visit www.go2intl.com